

MANISCOPIC

■ MT 1840





- Maximum lifting height: 17.55 m
- Capacity: 4000 kg
- Maximum forward reach: 13.08 m
- Hydraulic stabilizers
- Frame levelling: $\pm 9^\circ$
- Torque convertor

 **MANITOU**

MT 1840

 **Lifting capacity**4000 kg
 at 500 mm from forks heels
 Tipping load at maximum reach
 with stabilizers.....1110 kg
 Tear out force with bucket
 to ISO 83137500 daN

 **Lifting height**17.55 m
Times: unladen / loaded (in s)
 Lifting17.3/17.3
 Lowering.....12.7/12.6
 Extension boom.....16/16.5
 Retraction boom15.6/15
 Crowd5
 Dump.....4

 **Tyres**.....440/80-24

 **Forks** (mm)
 Length1200
 Width x thickness.....125 x 50
 Maximum distance between forks1040
 Carriage rotation126°

 **Multidisc brakes - hydraulically assisted on both axes.**

 **PERKINS Engine**
 Type1104D-44TA
 Capacity4 cylinders - 4400 cm³
 Power:
 (ISO/TR 14396)74.5 kW/101 HP at 2200 rpm
 Maximum torque.....400 Nm at 1400 rpm
 Direct injection
 Water cooling

 **Transmission**torque convertor
 Electro-hydraulic reversing shift
 4 speeds forward and reverse
 Maximum travel speed (kph)25

 **Hydraulics**
 Pumpgear type
 Pressure/capacity.....270 bar/170 l/min

 **Capacities**
 Cooling system20 l.
 Engine oil10,9 l.
 Hydraulic oil.....175 l.
 Transmission oil23 l.
 Fuel tank.....140 l.

 **Weight unladen**11630 kg
Overall width2.42 m
Overall height2.50 m
Turning radius (outside wheels)4.01 m
Overall Length6.27 m
Ground clearance0.43 m
Drawbar pull10000 daN

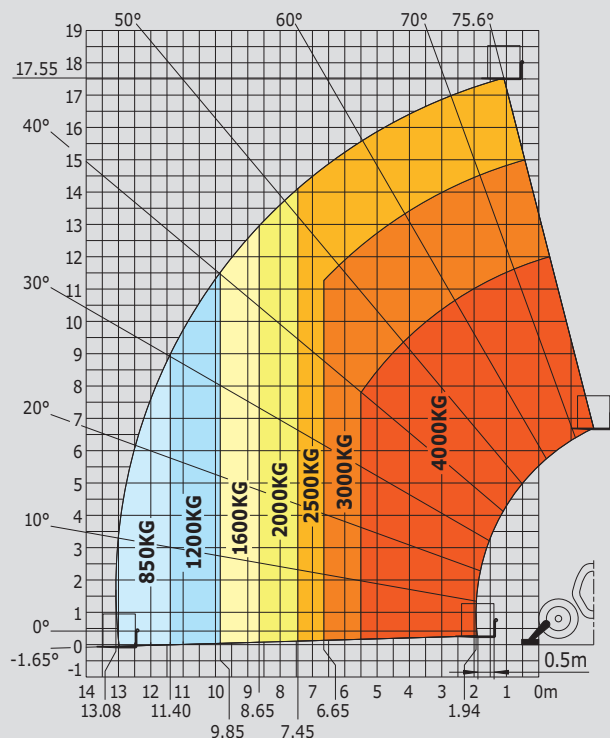

Under
 EN 1459
 annexe B

A	1200
B	3070
C	2044
C1	1929
D	6274
D1	6159
D2	4894
E	7474
F	1960
F1	1960
G	437
G1	420
G2	433
G3	302
H	9°
H1	9°
I	1160
J	892
K	1040
L	50
N	1908
O	125
P2	37°
P3	34°
R	3779
S	8788
T	4307
U1	2505
U2	2693
V	5592
V1	1285
V2	4009
W	2420
W1	3793
W2	1134
W3	2422
Y	12°
Z	114°

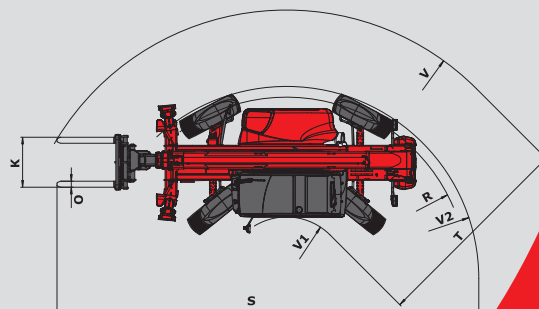
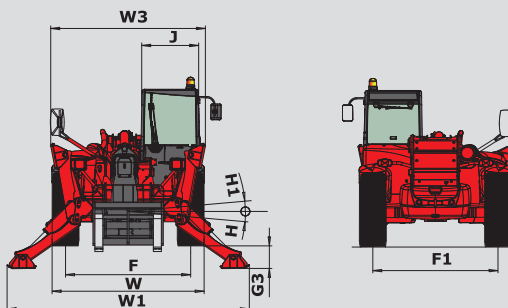
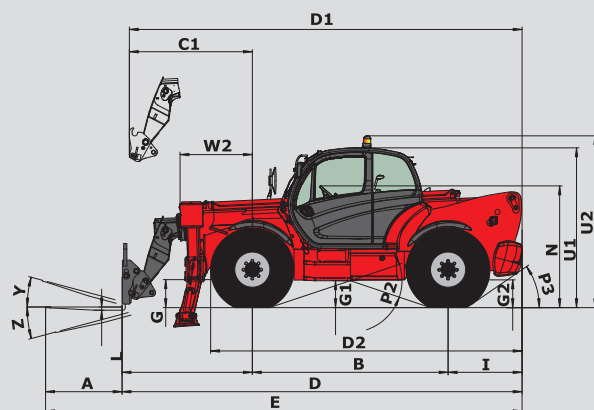

The specifications contained herein shall not bind the manufacturer and are subject to change without notice. This equipment described in this leaflet may be standard, optional, or unavailable, depending on the versions. For more details, contact your MANITOU dealer.

